

Tandem-Axle 6'1

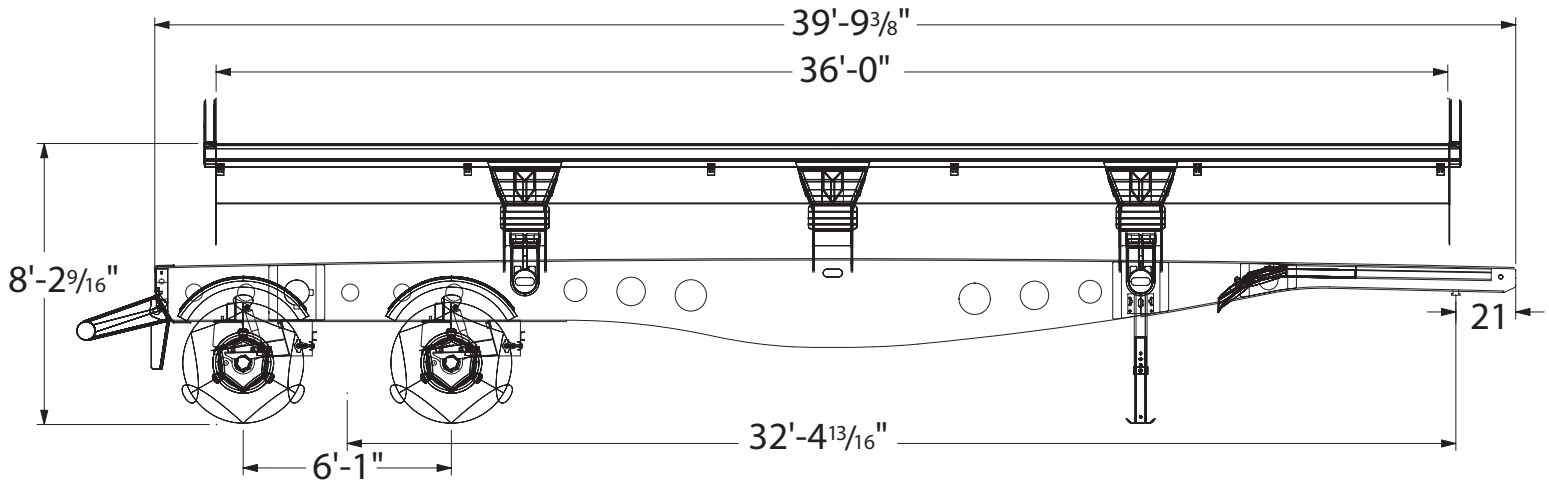

Length:	Tandem 39' 9"
Width:	102"
Height:	Tub Down 100" • In Dump Position 129"
Trailer Weight:	15,000 lbs
Tub Capacity:	36' Tub: 23 CU Yards
Dump Angle:	42 degrees
King Pin:	21"
Landing Gear:	Manual retracted with multiple height settings, 20" clearance
Suspension:	Tuthill AR23 Air Ride
Axles:	ArvinMeritor 25,000 lbs 5/8" wall
Wheels:	8.25 x 22.5 Accuride Steel
Tires:	16 ply 18/32" tread depth
Mud Flaps:	Ultra rubber spray suppressing with Sidump'r logo
Hydraulics:	3-stage, dual telescopic cylinder with integrated counter balance valve, electric over-hydraulic directional control valve, 1" hydraulic lines.
Cylinder:	3-stage single cylinder. As each stage extends out, the dump cycle becomes faster. More push and pull power than any 2-cylinder model. 2-year warranty.
Tub:	1 piece rolled AR400 tub. No center divider. Haul anything without the distraction of trying to work around the tub divider our competitors have.
Lights:	Grote 12 Volt rubber mount sealed lighting and harness system with 7 pole electrical socket.
Fenders:	Bolt on replaceable front and rear fenders, sloped at 10 degrees. Each rear wheel has its own independent fender.
Pivot Joints:	Composite bushing roller pin design requires no greasing.
Rear Push Block:	Bolt on with Sidump'r logo conforms to new Federal Under Ride Protection Law.
ABS:	Haldex 2S1M
Safety:	Red and white conspicuity markings & tub latching system meets D.O.T. secured load requirements at all times while traveling down the road!
Colors:	All CAT Yellow, Black, White, Grey, or any combination.
Options:	Aluminum Wheels, 24.5 Tires, Super Singles, Two Tone Paint, ABS, 2S2M or 4S2M, Electrical Tarp System, Digital Scale, Lift Axle

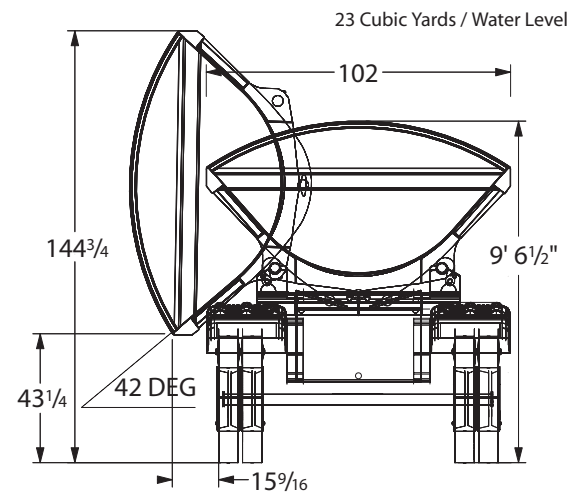

The Sidump'r Difference

1-888-743-8677 • 402-582-4830
www.sidumpr.com • sales@sidumpr.com