

INTERNATIONAL®
RH™ SERIES



THE INTERNATIONAL® RH™ SERIES





DELIVERING AT EVERY TURN.

The International® RH™ Series with the all-new International® S13 Integrated Powertrain

The RH Series has long been the answer for fleets looking for a rock-solid local and regional delivery solution. Optimized around a driver's needs, its turning radius, cost of ownership, and driver visibility figures are among the best in the industry. The RH Series is also available in a range of configurations, so you can spec it to match your specific business needs.

And now the RH Series takes it up a notch by adding the revolutionary International S13 Integrated Powertrain. Powerful, efficient, and easy to maintain, the S13 Integrated Powertrain brings a new level of productivity to regional delivery fleets everywhere.





CONFIGURATIONS THAT MEET THE NEEDS OF BUSINESS.



56" Hi-Rise Sleeper*

56" Hi-Rise Sleeper
with Roof Fairing

Day Cab with Roof Fairing

Day Cab

56" Low Roof Sleeper*

The International® RH™ Series is built to redefine the rules of productivity. Offered in numerous configurations, each one was designed using the input of drivers and fleets as well as over 100 years of experience in the commercial vehicle industry. Whether it's a day cab, hi-rise sleeper, or low roof sleeper, when you need a local or regional haul solution tailored to your business, there's an RH Series that delivers.

- ▶ Local to Regional-Haul Applications
- ▶ Van, Flatbed and Specialty Haul
- ▶ Fleet or Owner Operator

* Shown with optional sun visor



TWO STRONG CHOICES.



A26

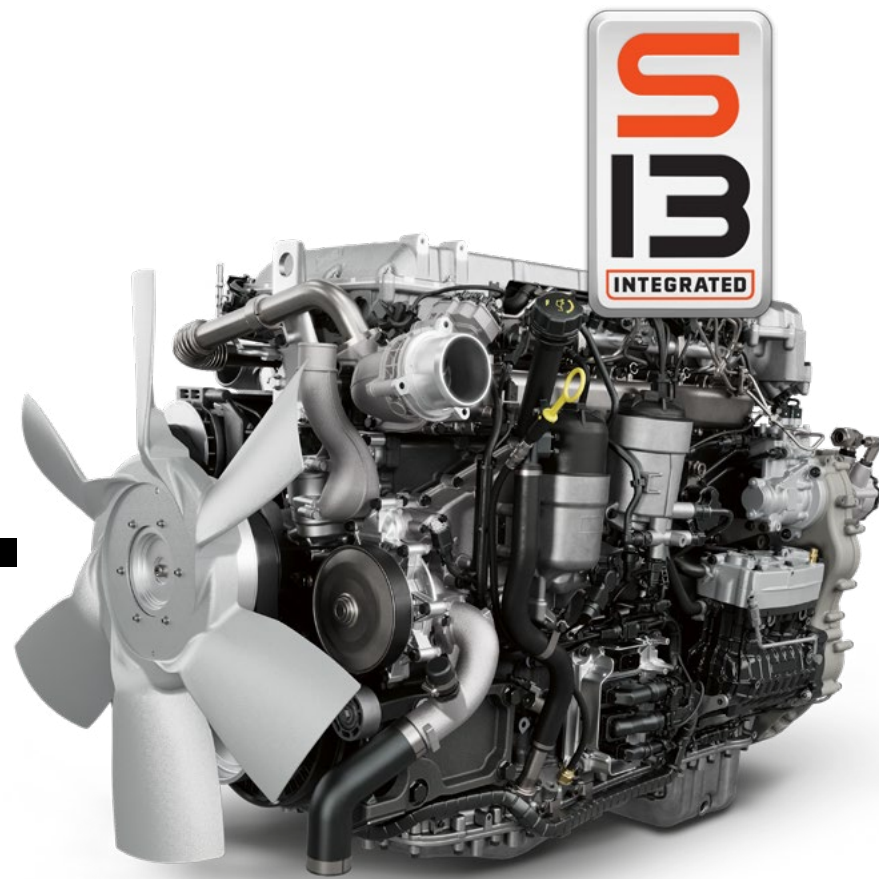

S13 INTEGRATED

No two businesses are the same. And while their vehicle needs may vary, their commitment to generating revenue is universal. That's why no matter which one you choose, every RH™ Series brings profit-boosting efficiency, uptime-boosting dependability, and driver-friendly usability.



CERTIFIED TO THRIVE.

Both the International® S13 and the International® A26 meet rigorous B10 design life standards for 1,200,000 miles.

The B10 designation is the mileage at which 10% of engines are expected to require a rebuild. Most competitors use a B50 designation where 50% of their engines are expected to require a rebuild at 1,000,000 miles. If your trucks are averaging 60,000 miles each year, that's the equivalent of running over three more years before your first major overhaul - real savings that can impact your bottom line.



ACHIEVING B10 DESIGN LIFE STANDARDS
International B10 standards require 90% of all engines to endure 1.2 million miles before a rebuild is required.



ADVANCED, INTEGRATED, MASTERFUL.

The International® S13 Integrated Powertrain was developed by a dream team of engineers located literally all over the world who were able to rethink, redesign, and reinvent what an integrated powertrain can be. The result is the S13 Engine, T14 Transmission and Dual Stage Aftertreatment system designed to work as one that's simple, easy-to-service and delivers stellar performance with superior operating economy.

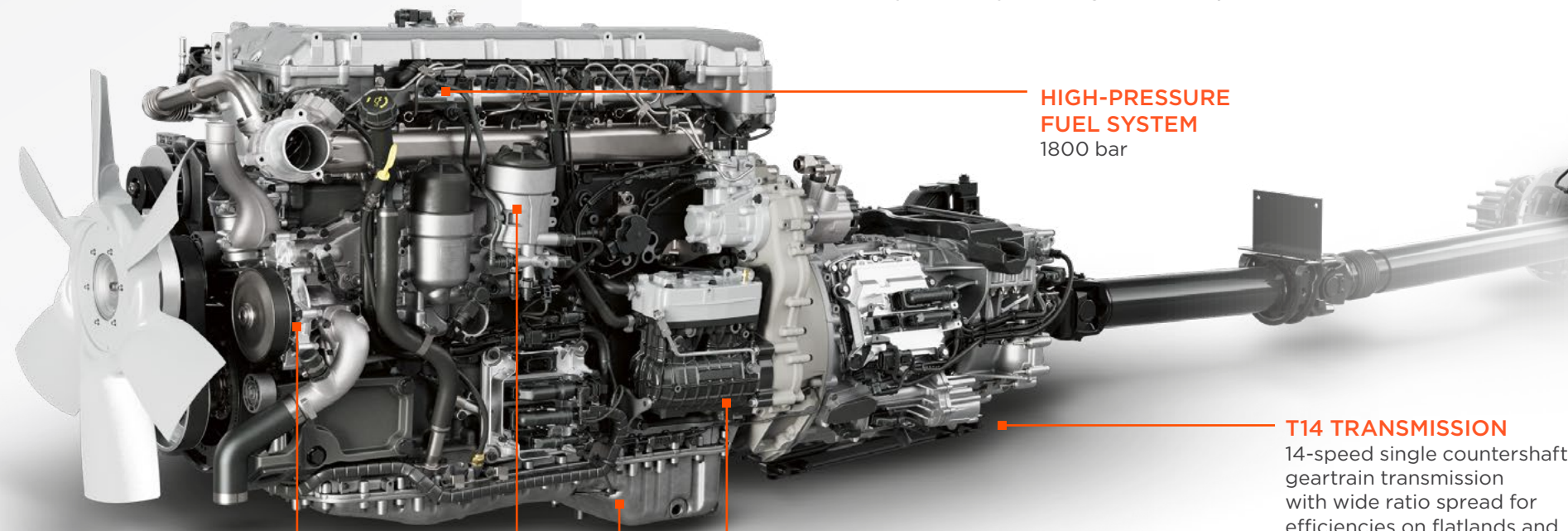

NO COOLED EGR
EGR cooler not required with this advanced engine design

ALUMINUM VALVE COVER

FIXED GEOMETRY TURBO
More reliable and efficient design

6-BLADE FAN
Converted from a 10-blade to a 6-blade for additional efficiency improvement

DUAL STAGE AFTERTREATMENT
• Compact design for more frame rail mounting space
• No active DPF regen needed

BEST-IN-CLASS ENGINE WARRANTY
Standard Engine Warranty 2 years, unlimited miles, unlimited hours
Optional Engine Warranties Up to 6 years; 600,000 miles
Optional Major Component Coverage Up to 7 years; 700,000 miles

HIGH-PRESSURE FUEL SYSTEM
1800 bar

T14 TRANSMISSION
14-speed single countershaft geartrain transmission with wide ratio spread for efficiencies on flatlands and performance on hilly terrains

AIR COMPRESSORS
• Single cylinder (iron)
• Two cylinder (aluminum)
• Two cylinder clutched (aluminum)

WATER PUMP
Low displacement, low parasitic losses

FUEL FILTER

OIL PAN
Aluminum pan provides corrosion protection



S13 INTEGRATED

Engine Type	Diesel, 4-Cycle
Configuration	Inline 6-Cylinder
Displacement	12.7L (777 cu. in.)
Bore & Stroke	4.96 in. & 6.54 in. (126 mm & 166 mm)
Compression Ratio	23:1
Aspiration	Fixed Geometry Turbocharger
Combustion System	1800 bar Common Rail
Engine Lubrication	42 Quarts (40L)
Total Engine Weight (Dry)	2,500 lbs. (1,134 kg)
Valves	4 Valves per Cylinder, Dual Overhead Camshaft
B10 Design Life	1,200,000 mi (1,931,000 km)

T14 TRANSMISSION

Deep low-end gearing and shifting smoothness, delivering efficiencies of a direct drive in an overdrive package
14 speed with 2 crawler gears
A lightweight, efficiently packaged, and robustly designed gearbox with unlimited GCW
Single countershaft transmission designed for simplicity and reliability

Transmission Base Warranty (includes towing)

Transmission	5 years; 750,000 miles (1,200,000 km)
Clutch	3 years; 350,000 miles (563,000 km)

Gear Ratios

Gear	Ratio	% Step
R2	12.60	
R1	16.23	
1	20.81	29%
2	16.16	29%
3	12.57	29%
4	9.76	29%
5	7.56	29%
6	5.87	29%
7	4.55	29%
8	3.53	28%
9	2.77	29%
10	2.15	29%
11	1.66	29%
12	1.29	29%
13	1.00	28%
14	0.78	-



SHIFT WHAT'S POSSIBLE

Any engine, no matter how well designed, is only as good as the transmission it's mated to. Delivering the power to the road in a smooth, predictable manner is no small feat when you consider the amount of torque of heavy-duty trucks. By starting with a clean sheet of paper, our engineers behind the S13 Integrated Powertrain were able to make sure the engine and transmission work in perfect harmony. The result is the fully automated T14 manual transmission with 14-speed overdrive. Its shifts are seamless and require no input from the driver in terms of being in the right gear at the right time.

SHIFT ACTUATORS

- Shift actuator packaging was designed specifically for automated functionality (rather than adapted from a manual), allowing for more compact gearbox housing

VARIABLE OIL LEVEL UPPER RESERVOIR

- Oil is pumped to the reservoir under lower loads to reduce parasitic losses, allowing for the continuous lubrication of gears by the oil sprayers

PLANETARY GEARS

- The planetary gear set eliminates the need for a dedicated reverse gear, shortening the gearbox and allowing for better packaging within the chassis

SINGLE COUNTERSHAFT

- A single countershaft with helical gears lowers the overall weight of the unit without compromising the durability or performance of the transmission

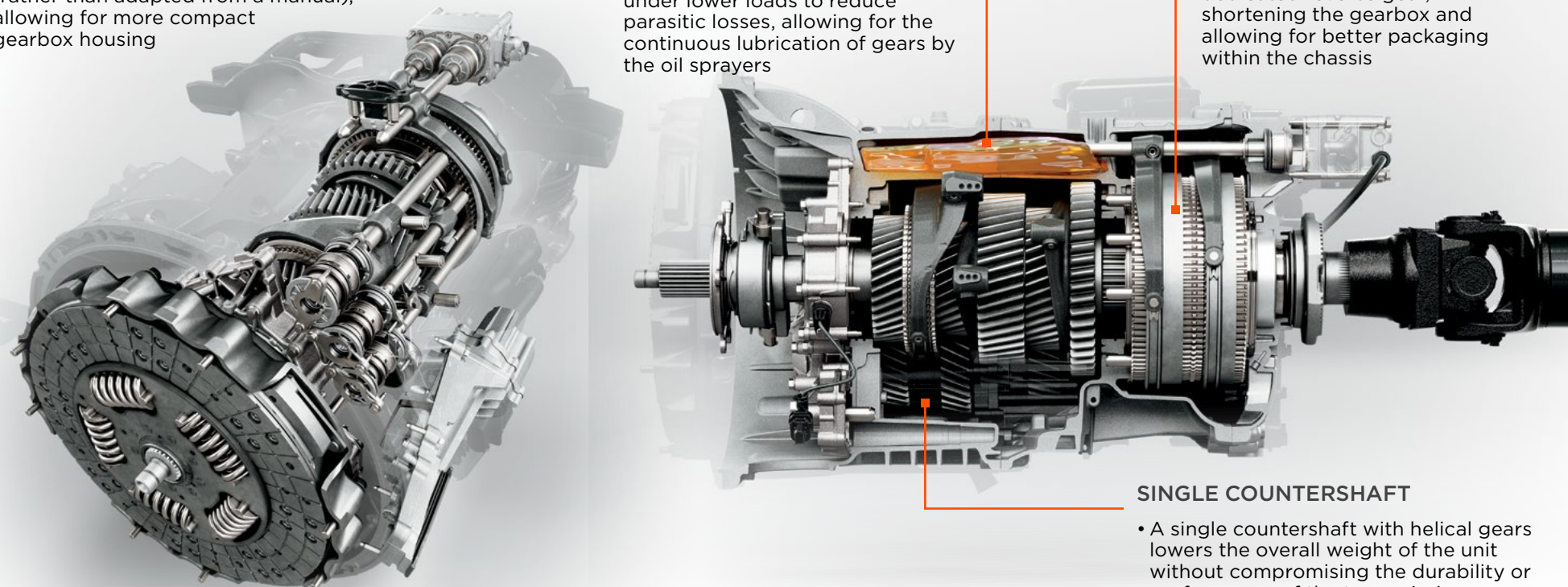

THE TRANSMISSION CONTROL MODULE (TCM)

Features like predictive cruise control, neutral coast, downhill speed control, and predictive shifting, can now be found in one module — the TCM. Combining these features into one module means the vehicle feels more natural and intuitive and, ultimately, more efficient.

The transmission has an electronically controlled clutch actuator that works in sync with the engine to deliver faster, smoother shift performance. Since it does not consume air during complicated maneuvers, like when you're backing a trailer into a tight loading dock, the driver never needs to stop and let the air recharge.



DOWNHILL SPEED CONTROL

Cruise control using the engine brake to slow down to a specific speed. Control at the wheel to manage speed going downhill.

ECO-COAST

Disengages the driveline when traveling downhill, using the momentum of the vehicle to save fuel.

MANEUVERING MODE

Gives the driver more control of the vehicle at low speeds for specific movements, such as reversing into a loading dock, connecting to a trailer, or other low-speed maneuvers. Torque value for pedal input is reduced. This mode allows the clutch to slip more easily for slow and smooth performance.

DRIVER SHIFT MODES

Three different shift modes (optional) for ultimate control for the driver

- ▶ Economy — Predictive shifting with fuel efficiency focus
- ▶ Performance — Perfect balance
- ▶ Performance+ — Shifting at peak power with focus on performance



CREEP MODE

Allows the vehicle to automatically start moving when the brake pedal is released while the transmission is in gear. Useful in high traffic and other events where constant vehicle movement is necessary without the use of the accelerator pedal.





A26

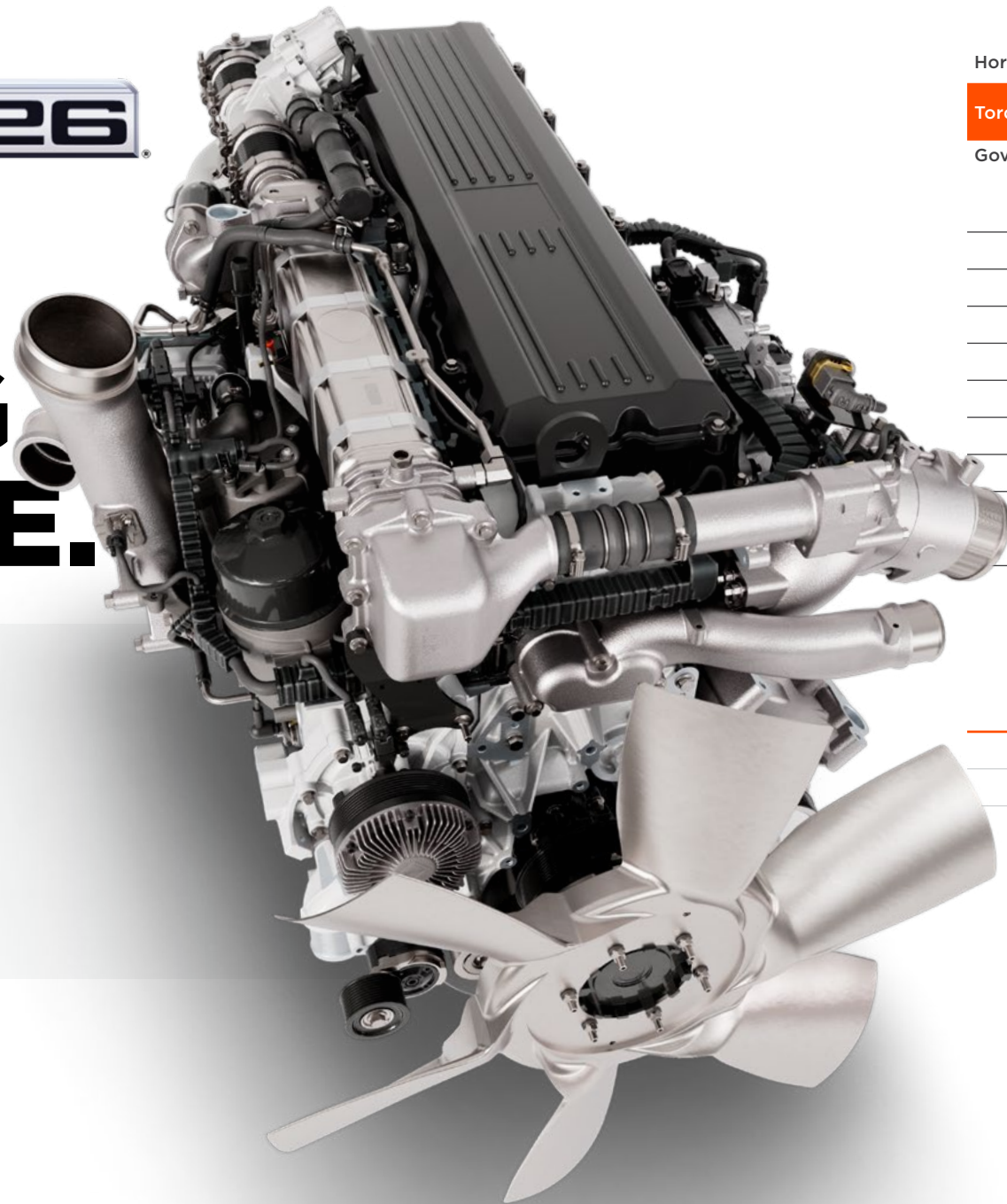

A LEGACY OF OUTSTANDING PERFORMANCE.

THE INTERNATIONAL® A26 IS PACKED WITH THE FEATURES AND CAPABILITIES THAT MAKE IT A REGIONAL HAUL WORKHORSE

The A26 produces up to 515 hp and 1,850 lb.-ft. of torque. Every component of the A26 has been carefully engineered for reduced weight while delivering uncompromising uptime and performance.

Horsepower [BHP @ RPM]	400 - 515 @ 1700	410 @ 2100
Torque [LB-FT @ RPM]	1,450 - 1,850 @ 900	1,450 @ 900
Gov. Speed [RPM]	1,800	2,100

Engine Type	Diesel, 4-Cycle
Configuration	Inline 6-Cylinder
Displacement	12.4 L (758 cu. in.)
Bore & Stroke	4.96 in. & 6.54 in. (126 mm & 166 mm)
Compression Ratio	20.5:1
Aspiration	Variable Geometry Turbocharger
Combustion System	Direct Injection 2500 bar HPCR
Engine Lubrication	42 Quarts (40L)
Total Engine Weight (Dry)	2,314 lbs. (1,050 kg)
Valves	4 Valves Per Cylinder, Single Overhead Camshaft
B10 Design Life	1,200,000 mi (1,931,000 km)



Best-In-Class Engine Warranty

Standard Engine Warranty	2 years, unlimited miles, unlimited hours
Optional Engine Warranties	Up to 6 years; 600,000 miles; unlimited hours
Optional Major Component Coverage	Up to 7 years; 700,000 miles; unlimited hours



The single canister after-treatment system features a simple, easy-to-service design that is both compact and light weight while providing ample ash retention for extended service intervals.

The A26 engine delivers the strength you need in a compact and lightweight package and can be paired with a choice of transmissions to match the needs of your business.

Variable geometry turbocharger — Titanium compressor wheel provides excellent longevity. Serviceable electronic actuator increases uptime and reduces service cost.

Jacobs Engine Brake® — Variable geometry turbocharger improves engine braking performance, particularly at low- to mid-RPMs and higher altitudes.

2500 Bar High-Pressure Common Rail Fuel System — Delivers maximum fuel injection pressure (36,300 psi) to reduce emissions and fuel consumption, with multiple injection events for smooth and quiet operation.

Lightweight design — Compacted Graphite Iron crankcase, shot-peened aluminum flywheel housing, composite valve covers, and a hollow camshaft deliver a lightweight design, maximizing payload capacity.

Cold starting — Cold starting down to -40°F with available oil heater, coolant heater, and cold start system with unaided cold starting down to 10°F for dependable starting in extreme climates or when plug-in heating isn't available.



A VISIBLE DIFFERENCE.

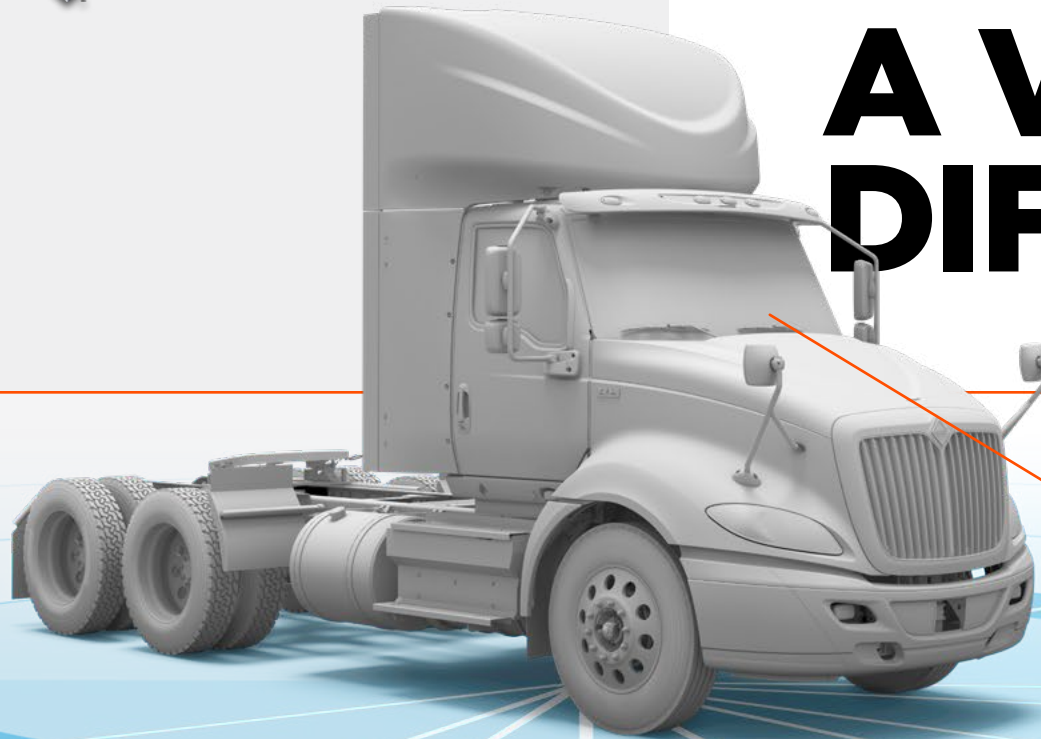

The International® RH™ Series interior was designed based on a meticulous study of interaction points between the driver and truck - everything from what a drivers see to how they move and react in virtually any situation. That's why the RH Series has been designed with a large swept-back windshield, optimized mirror placement and an aerodynamic sloped hood for a clearer view.

Forward visibility is among the industry's best at as little as 21'. This means objects closer to the vehicle are more visible to the driver, improving safety.

DIRECT VISIBILITY

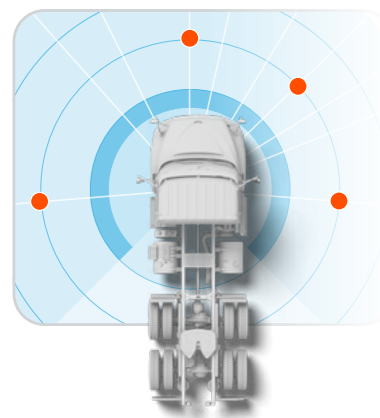

INDIRECT VISIBILITY

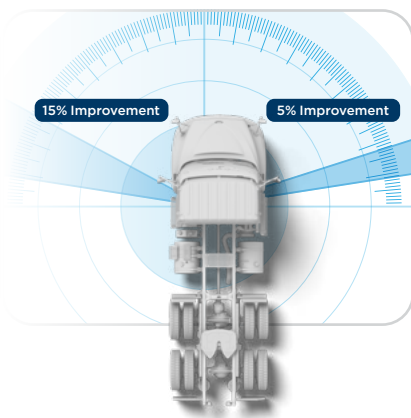

The shaded areas represent how indirect visibility has been optimized by reshaping the doors and side windows, and repositioning the cab mirrors so drivers turn their heads 15% less on the driver side and 5% less on the passenger side. This increased visibility reduces driver stress and neck strain to enhance productivity.

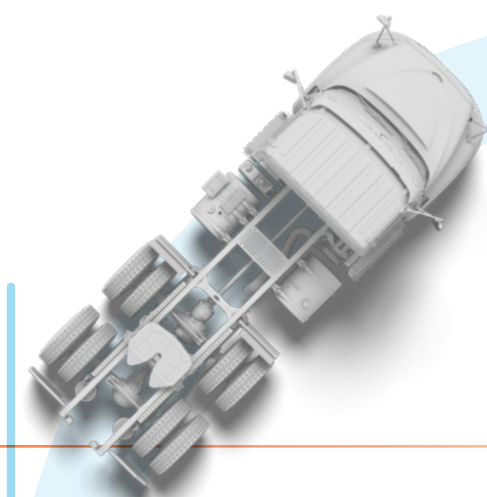

TURNING RADIUS

**50°
Inside Cut**

OUTSTANDING MANEUVERABILITY

You need optimal maneuverability to navigate through tight city streets or cramped loading docks. The RH Series is engineered to provide an inside wheel cut of up to 50° which delivers a curb-to-curb turning radius of only 27' 10", saving drivers time and boosting productivity.*



**27' 10"
Curb to Curb**

*With a 152" cab to axle (wheelbase is 215")



KEEPING YOU ON THE ROAD TO PROFITABILITY.

Uptime is more than a word in the International® RH™ Series. It's an unwavering commitment to deliver a truck that's as reliable and easy to service as the road is long.



In-cab electrical panel



Laser-etched steering wheel controls

- ▶ **Driver controls and instrumentation** are based on robust industry-standard SAE J1939 electrical architecture, with a premium gauge cluster and switches designed to keep drivers focused and maximize uptime.
- ▶ **Steering wheel control labels** are laser-etched for maximum readability and durability.
- ▶ **Key interior fasteners** are exposed for more intuitive access and easier servicing.
- ▶ The powerful **HVAC system** employs advanced automotive heating and cooling technology to deliver optimal comfort and reliability. The system endured rigorous testing in extreme temperatures to deliver best-in-class visibility and comfort.
- ▶ The **max defrost** feature in the HVAC system helps clear windows faster in colder climates, providing quicker, clearer visibility for increased uptime and less waiting.
- ▶ **Cab wiring** features a power distribution module that's located inside the cab, protected from the elements.
- ▶ The **hood** opens wide for easy serviceability. It features torsion bar lift assist to enable lifting with one hand and gas strut control to prevent the hood from closing too quickly.
- ▶ The easily removable **3-piece bumper** provides quick service access to front components.
- ▶ Standard **LED headlamps** last longer than traditional headlamps while delivering brighter light pattern and intensity.

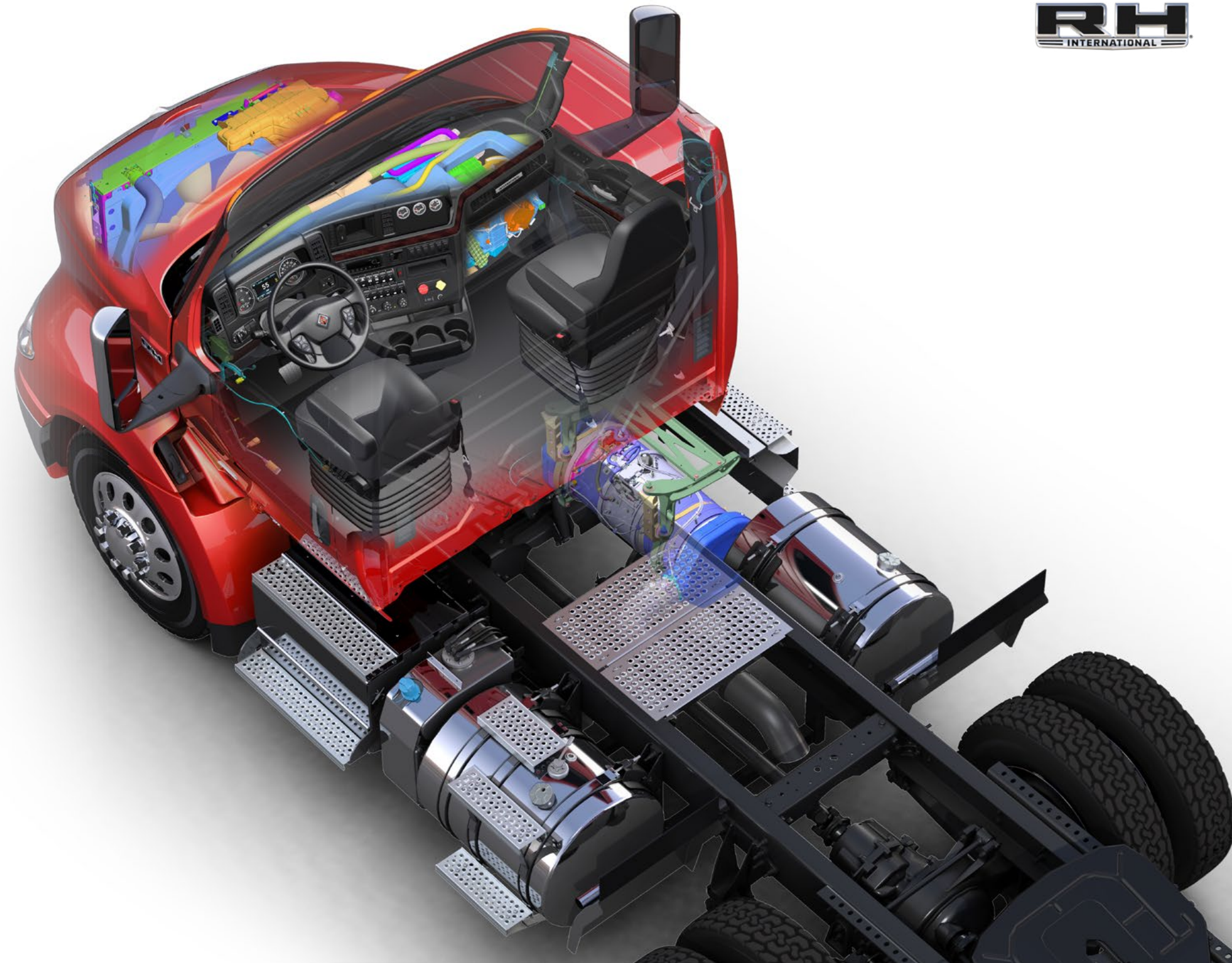



DRIVERFIRST™

LISTENING AND DELIVERING.

From the very beginning, priority #1 for the International® RH™ Series was to design a truck that drivers would really want to drive. To achieve this goal, we turned to the people who know driving best - real truck drivers.

These professionals gave us honest, priceless input during numerous research sessions and driver clinics. Then we set about redesigning, fine-tuning, and retesting until drivers agreed, "This is the truck I've always wanted to drive."

That's how the RH Series became the most driver-centric truck on the road today. It has more intuitive controls, enhanced visibility, a quieter cab, critical information at your fingertips, and dozens of other smart features that help keep a driver comfortable and in control over the long haul.



Diamond Elite



AN INTUITIVE, CUSTOMIZABLE COMMAND CENTER.

Every detail inside the International® RH™ Series cab has been carefully designed, measured, and clinic-tested to benefit the driver. The gauges are optimized for readability, usability and position, so key information and alerts are precisely where they need to be. The standard premium gauge cluster features a customizable digital display that lets drivers intuitively select the information they prefer in a variety of situations.

The color, illumination, legibility—and even the type font and size of gauges—is designed to deliver optimal viewing in varying light conditions, maximizing alertness and minimizing eye fatigue.

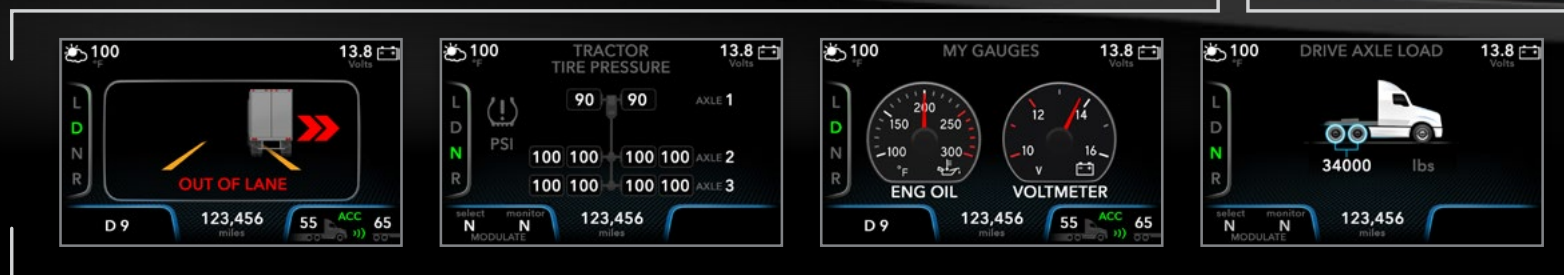

Driver safety is always a priority. That's why the RH Series includes standard Bendix® Wingman® Fusion™ system with collision mitigation technology, adaptive cruise control, lane departure warning (pictured here), over-speed alert, and stationary vehicle braking. You can also select from a number of proven stand-alone safety systems to meet your specific needs. Bendix Wingman Advanced™ and Wabco OnGuard ACTIVE™ are also available.

The premium gauge cluster includes a customizable digital display which provides a wealth of information for the driver, including:

- Real-time fuel economy
- Axle load*
- Custom gauge settings*
- Safety indicators*
- Digital speedometer
- Tire pressure*

*When added with optional feature code for required sensors



TAILOR THE INTERNATIONAL[®] RH[™] SERIES TO SUIT YOUR DRIVER AND FIT YOUR BUSINESS.

Cab Features

- Cab Trim Panels
- Door Trim
- Trim Inserts
- Instrument Panel
- Gauge Cluster
- Accent Color
- Sun Visors
- Lighting
- Window Controls
- Lock Controls
- Cup/Bottle Holders
- Overhead Console
- USB Accessory Port

Classic

Easy-to-Clean, Soft Touch Vinyl
Easy-to-Clean, Soft Touch Vinyl
Neutral
Black
8-Gauge, 3.5" Display with Odometer and Trip Optional: Premium 8-Gauge, 5" Color Display with Virtual Gauges
Neutral
Two
LED
Power
Manual or Power
Four
Molded Plastic with Retainer Nets and CB Radio Housing and Paper Towel Storage in Sleeper Configuration
Up to 4

Diamond

Mineral Grey Teak
Easy-to-Clean, Soft Touch Vinyl with Mineral Grey Teak Inserts and Chrome Handle
Mineral Grey Teak Trim
Black
8-Gauge, 3.5" Display with Odometer and Trip Optional: Premium 8-Gauge, 5" Color Display with Virtual Gauges
Mineral Grey Teak
Two
LED
Power
Power
Four
Molded Plastic with Retainer Nets and CB Radio Housing and Paper Towel Storage in Sleeper Configuration
Up to 4

Diamond Elite

Satin Mahogany
Easy-to-Clean, Soft Touch Vinyl with Satin Mahogany Inserts and Chrome Handle
Satin Mahogany Trim
Black
8-Gauge, 3.5" Display with Odometer and Trip Optional: Premium 8-Gauge, 5" Color Display with Virtual Gauges
Satin Mahogany
Two
LED
Power
Power
Four
Molded Plastic with Retainer Nets and CB Radio Housing and Paper Towel Storage in Sleeper Configuration
Up to 4



AVAILABLE CONFIGURATIONS



Day Cab

113" BBC
Local, Regional, Bulk and Specialized Applications



56" Low Roof Sleeper

113" BBC
Regional Line Haul, Bulk, Flatbed and Specialized Applications



56" Hi-Rise Sleeper

113" BBC
Local to Regional-Haul and Specialized Application

GVW

- ▶ 32,000 – 60,000 lbs.

BBC/BA

- ▶ 113"/50"

Day Cab Configurations

- ▶ 56" Low Roof Sleeper
- ▶ 56" Hi-Rise Sleeper

Wheelbase Options

- ▶ 140 – 226" 4x2
- ▶ 152 – 270" 6x2, 6x4

Axle Configurations

- ▶ 4x2, 6x2, 6x4

Rear Axle

- ▶ SINGLE REAR AXLE (4x2)
 - Meritor: 23,000 lbs.
 - Dana Spicer: 23,000 lbs.
- ▶ TANDEM REAR AXLE (6x4)
 - Meritor: 40,000 – 46,000 lbs.
 - Dana Spicer: 40,000 – 46,000 lbs.

Front Axle

- Hendrickson: 12,350 – 14,000 lbs.
- Dana Spicer: 12,350 – 14,000 lbs.
- Meritor: 12,350 – 14,000 lbs.

Frames

- ▶ Heat-treated Alloy Steel 120,000 PSI

Front Suspension

- ▶ Spring Monoleaf: 12,350 – 13,200 lbs.
- ▶ Parabolic Taperleaf: 12,350 – 14,000 lbs.

Rear Suspension

- ▶ AIR SINGLE
 - International: 20,000 lbs.
- ▶ AIR TANDEM
 - International: 40,000 lbs.
 - Hendrickson: HAS 40,000 – 46,000 lbs.

Electrical System

- ▶ ALTERNATORS
 - Leece-Neville: 12 Volt, 160, 210, 240, 325* Amp
 - Delco Remy: 12 Volt, 165*, 200, 300* Amp
- * brushless type alternator
- ▶ BATTERY SYSTEMS
 - Fleetrite: 12 Volt 1980 – 9200 CCA
 - JCI: 12 Volt 2250 – 3000 CCA
 - Deka: 12 Volt 2920
 - Enersys Odyssey: 12 Volt 3450 – 4600 CCA

Exhaust System

- ▶ Single Canister After Treatment Device, Frame Mounted Right Side Under Cab
- ▶ Horizontal or Vertical Exhaust

Brakes

- ▶ Air Disc Brakes with Automatic Traction Control and Electronic Stability Control
- ▶ Air Drum Brakes with Automatic Traction Control and Electronic Stability Control

Integrated Powertrains

- ▶ International® S13 12.74L
 - 370 – 515 hp
 - 1,450 – 1,850 lb.-ft.
- ▶ International® T14
 - 14-speed automated manual transmission

Engines

- ▶ International® A26: 400 – 515 hp and 1,450 – 1,850 lb.-ft.

Transmissions

- ▶ Automated Manual Transmissions
 - Eaton Endurant: 11, 12 speed
 - Eaton Fuller UltraShift PLUS: 13, 18 speed
 - Eaton Fuller Advantage: 10 speed
- ▶ Manual Transmissions
 - Fuller: 10, 13, 18 speed
- ▶ Automatic Transmissions
 - Allison 3000: 6 speed

Fuel Tanks

- ▶ 70 – 120 Gallon, Dual, Non-Polished or Polished Aluminum, Mounted Back of Cab or Under Sleeper
- ▶ 70 – 120 Gallon, Single, Non-Polished or Polished Aluminum, Mounted Back of Cab or Under Sleeper



Sleeper Features

	Classic	Diamond	Diamond Elite
12-Volt Power Supply	Standard	Standard	Standard
Trim Panels	Easy-to-Clean, Soft Vinyl Neutral Trim Panels	Easy-to-Clean, Soft Touch Vinyl with Mineral Grey Teak Accents	Easy-to-Clean, Soft Touch Vinyl with Satin Mahogany Accents
Headliner	Soft Vinyl	Soft Vinyl	Soft Vinyl
Sleeper Windows	Standard	Standard	Standard
Windshield Curtain	Optional	Optional	Optional
Sleeper Control Panel	Standard	Standard	Standard
Microwave Accommodation	Optional	Optional	Optional
TV Accommodation	Optional	Optional	Optional



56" Low Roof Sleeper Features

	Classic	Diamond	Diamond Elite
Overhead Storage	Two Airline-Style Cabinets Standard, with an Option for Two Additional	Two Airline-Style Cabinets Standard, with an Option for Two Additional	Two Airline-Style Cabinets Standard, with an Option for Two Additional

56" Hi-Rise Sleeper Features

	Classic	Diamond	Diamond Elite
Overhead Storage	Two or Four Compartments with Netting	Two Compartments with Netting or Doors	Two Compartments with Netting or Doors
Rear Wall Storage	Optional	Optional	Optional

Diamond Elite





CRITICAL VEHICLE HEALTH DATA AT YOUR FINGERTIPS.

OnCommand® Connection Advanced Remote Diagnostics transforms raw vehicle data into actionable insights to help you stay in front of potential vehicle issues and keep your International® RH™ Series at peak performance.

OnCommand® Connection

FEATURES INCLUDE:

- Reports on vehicle health issues that include severity ratings, likely needed parts and service, and recommended actions
- Comprehensive vehicle health reports that include performance data, fault history, and more
- Up-to-date GPS location with customizable geofencing reports that can help ensure vehicles are where they need to be
- Insights delivered how you need it – via our online portal, your email inbox, a mobile app, and more.

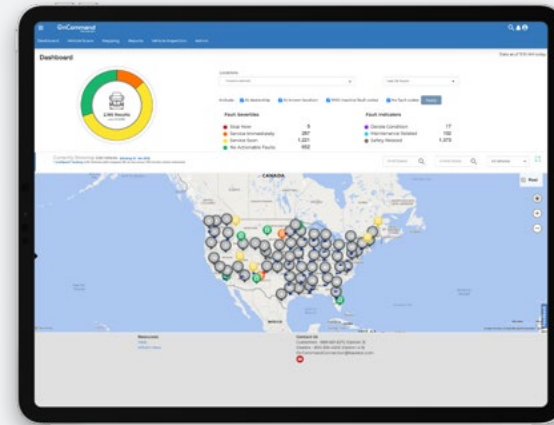
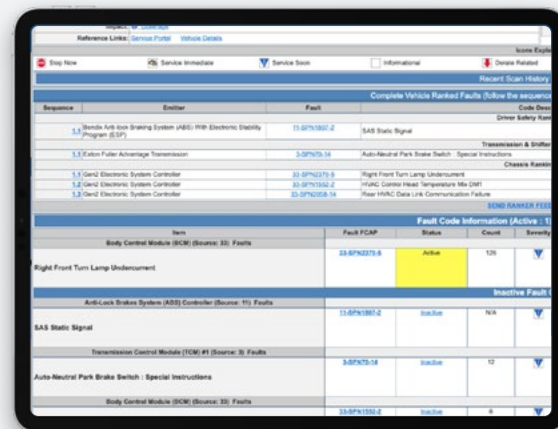

TAKE YOUR PERFORMANCE TO THE NEXT LEVEL

We offer additional tools powered by OnCommand® Connection designed to give your business and operations that extra edge.

OTA Programming	Ensure peak performance with remote software calibration updates to the S13 Integrated Powertrain, anytime or anywhere
Fleet Health Monitoring	Reduce breakdowns with weekly reports on vehicles at highest risk of roadside failure
Advanced Preventive Maintenance	Optimize PM spending with data-driven, customized interval recommendations for your trucks
Advanced Fuel Analytics	Improve fleet efficiency with reports on key driver behaviors and other factors that affect fuel economy (i.e., cruise control use, idle time, harsh acceleration)

TRANSPARENT SERVICE COMMUNICATIONS WITH YOUR DEALER

Knowing when your vehicle's service and repair events will be complete is critical to keeping your business up and running. International® 360 makes the entire process faster and easier to manage.

- Updates via text and email keep you informed on the status of vehicles in service, including estimated time of completion
- Integrates telematics, dealer parts inventory, and other vital information into one easy-to-use tool
- Centralizes vehicle health data, service history, and more



New International® RH™ Series models come standard equipped with factory-installed telematics and five years of service, including:

- OnCommand® Connection Advanced Remote Diagnostics
- International® 360

- Over-the-Air Programming
- Fleet Health Monitoring
- Advanced Preventive Maintenance
- Advanced Fuel Analytics
- TPMS Integration (requires TPMS system installed on truck)
- Gateway Integrations



WHEN COMBINED, THESE SOLUTIONS CAN HELP FLEETS SAVE UP TO \$5,000 OR MORE OVER FIVE YEARS*

*depending on annual miles driven and other operational conditions



DRIVING PROFITABILITY

MORE TIME ON THE ROAD AND LESS TIME WAITING FOR REPAIRS

We understand making money means keeping your vehicles on the road. That's why uptime is so important to us. Dependable equipment spec'd for your needs or requirements is just the beginning. We also focus on fuel economy, preventive maintenance, optimized service intervals, and more to make sure the low cost of ownership of our vehicles helps keep you in the black.

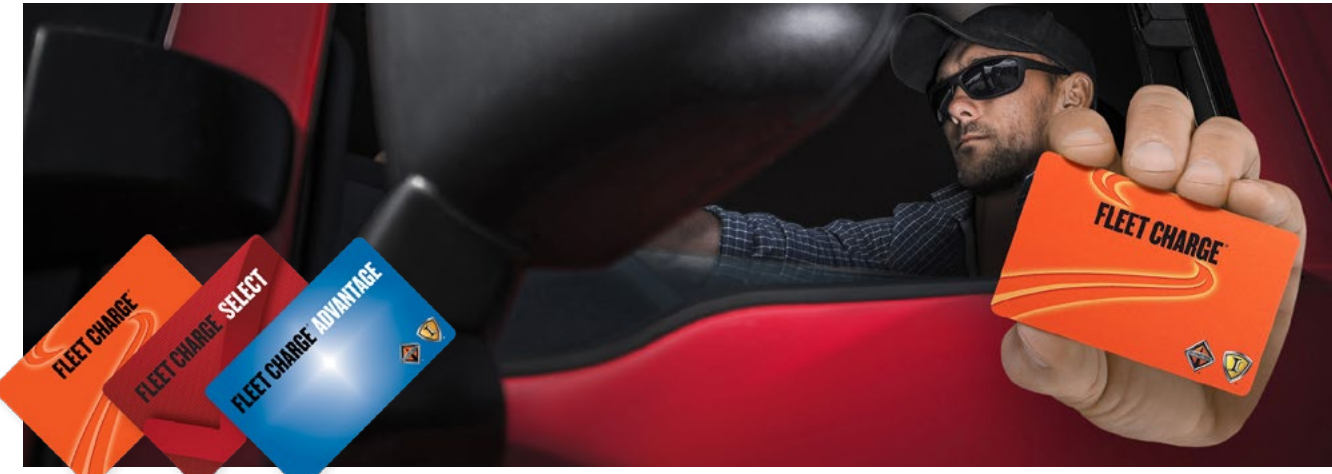

Maximum Uptime – Repair before Failure 

Prognostics that move unplanned repairs to planned. Optimizing maintenance using vehicle performance and predictive data.

Predictive Parts Stocking 

Dealer parts inventory management uses AI and telematics data to predict stocking needs. This ensures the best parts are on dealer shelves to support customers.

NAVISTAR FINANCIAL. UNLOCK YOUR POTENTIAL.

Navistar Financial offers flexible solutions to fit your financing needs, helping you secure the best products for your specific situation. Whether you're a loan customer or a lease customer the Navistar Financial team can provide you with the best option suited to your business.



For more information or to contact Navistar Financial, scan the QR code.

OVER 700 INTERNATIONAL® DEALER LOCATIONS + OVER 400 LOVE'S TRUCK CARE & SPEEDCO LOCATIONS =

OVER 1,100 TOTAL SERVICE LOCATIONS



TRUCK CARE

Our partnership with Love's Truck Care & Speedco adds 400+ additional locations for quick, conveniently located access to light mechanical and select warranty work*.

PARTS YOU NEED WHERE AND WHEN YOU NEED THEM

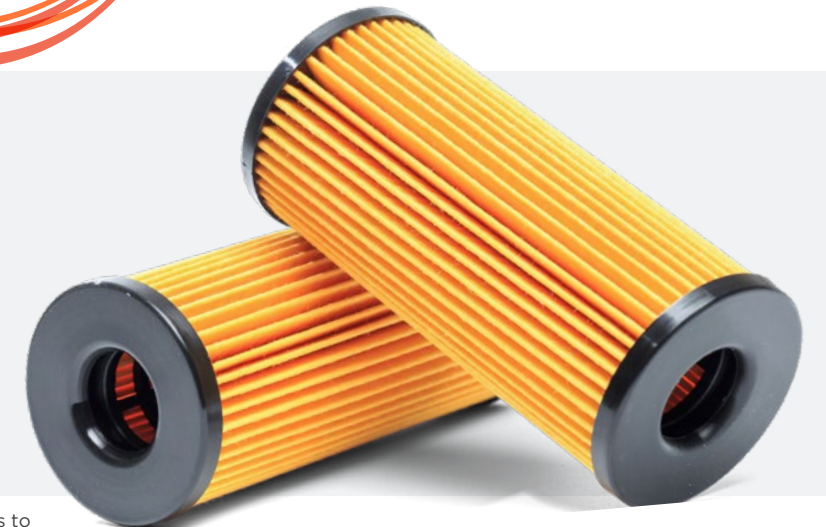

* Warranty-covered parts must be a certified International installed part for International Truck dealer service locations to honor warranty. Love's and Speedco locations in Texas and Louisiana cannot perform warranty services.



Note: The information and conclusions contained herein are believed to be correct at time of publication, but do not necessarily apply to similar vehicles with different specifications or with production dates after the production of this publication. Vehicles with different specifications or later dates of production may yield different results. Vehicle specifications are subject to change without notice. TAD17012 11/2023 ©2023 NAVISTAR Inc. All rights reserved. All marks are trademarks of their respective owners.